

CT-SA

Hochleistungs-Kraftspannfutter
High Performance Milling Chuck
Mandrino forte serraggio

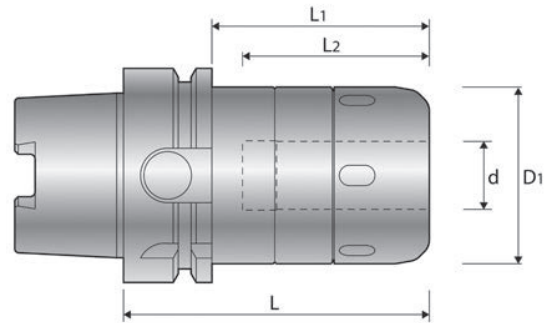

- ▶ **Unübertroffene Spannkräfte**
- ▶ **Hohe Rundlaufgenauigkeit**
- ▶ **Schnelle & einfache Werkzeugspannung**
- ▶ **Großer Spannbereich mittels MC-Spannhülsen**
- ▶ **Mehr Produktivität durch höheres Spanvolumen**

- ▶ **Unsurpassed clamping forces**
- ▶ **High run out accuracy**
- ▶ **Quick & easy tool clamping**
- ▶ **Large clamping range by using MC-Straight Collets**
- ▶ **Increased productivity due to higher chip volume**

- ▶ **Elevatissime forze di serraggio**
- ▶ **Elevata concentricità**
- ▶ **Bloccaggio rapido e semplice dell'utensile**
- ▶ **Grande capacità attraverso MC-Bussole**
- ▶ **Grande rigidità radiale**

CT-SA



Halter Holder Mandrino	d	D ₁	L	L ₁	L ₂	Preis Price Prezzo
HSK63A -CT20SA -90	20	52	90	64	60	€ 229,00
C6 -CT20SA -90	20	52	90	68	75	€ 269,00
SK40 -CT20SA -90	20	52	90	71	80	€ 179,00
SK50 -CT32SA -105	32	73	105	86	120	€ 249,00
BT40 -CT20SA -90	20	52	90	63	80	€ 179,00
BT50 -CT32SA -105	32	73	105	67	120	€ 249,00

HSK-A mit Kühlmittelübergabeeinheit.
 Haken-Spannschlüssel im Lieferumfang enthalten.

HSK-A with coolant unit.
 Hook spanner included in delivery.

Tubo del refrigerante HSK e
 chiave inclusi nella consegna

MC zur Durchmesser-Reduzierung
 for reduction of diameter
 Per la riduzione del diametro

MC-OH metallisch dichtend für IKZ
 metal sealing, inner coolant
 Sigillato per refrigerante interna

Spannhülsen Collets Pinze	für Halter for Holder per Mandrino	Preis Price Prezzo
MC20 6, 8, 10, 12, 16	CT20SA	€ 25,00
MC32 6, 8, 10, 12, 16, 20, 25	CT32SA	€ 28,00
MC20-OH 6, 8, 10, 12, 16	CT20SA	€ 30,00
MC32-OH 6, 8, 10, 12, 16, 20, 25	CT32SA	€ 33,00



CT-SA POWER SET



Stableuchte mit Magnetfuß
penlight with magnet
lampada magnetica

inklusive
inclusive
incluso

- Set:** 1 x Aufnahme CT20SA-90
- 1 x** Spannschlüssel HS-2-20
- je** 1 x MC-Spannhülse d 6, 8, 10, 12, 16 mm

- Set:** 1 x Milling Chuck CT20SA-90
- 1 x** Spanner HS-2-20
- each** 1 x MC-Collet d 6, 8, 10, 12, 16 mm

- Set:** 1 x Mandrino CT20SA-90
- 1 x** Chiave HS-2-20
- per** 1 x Pinza MC d 6, 8, 10, 12, 16 mm

MC

MC-OH

MC-C



MC zur Durchmesser-Reduzierung | reduction of diameter | per la riduzione del diametro

MC-OH für innere Kühlmittelzufuhr | for inner coolant | per refrigerante interna

MC-C für Peripheriekühlung | for side-through coolant | per refrigerazione periferica

DIN 69893
ISO 12164



ISO 26623-1



DIN 69871
ISO 7338

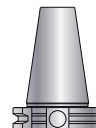

MAS-BT
JIS B6339

SET	HSK63A		Polygon C6		SK40 / BT40	
	List Price	Power-Box-Price	List Price	Power-Box-Price	List Price	Power-Box-Price
Set mit MC-Spannhülzen Set with MC-Collets Set con Pinze MC	€ 590,00	€ 329,00	€ 607,00	€ 339,00	€ 518,00	€ 289,00
Set mit MC-OH Spannhülzen Set with MC-OH Collets Set con Pinze MC-OH	€ 635,00	€ 349,00	€ 650,00	€ 359,00	€ 562,00	€ 309,00
Set mit MC-C Spannhülzen Set with MC-C Collets Set con Pinze MC-C	€ 759,00	€ 419,00	€ 776,00	€ 429,00	€ 688,00	€ 379,00

Einschraubfräser-Aufnahme

Super Rigid Modular Chuck

Mandrini avvitabili



Milling Chuck + Long Indexable Tool

❌ *Vibration*
 ❌ *Deflection*
 ❌ *Lower Cutting Conditions*

Longer GPL (175mm)

Chattered and uneven

Super Rigid Modular Arbor + Modular Mill

Avoid interference and make total tool length shorter

Shorter GPL (120mm)

✓ *Less Vibration*
 ✓ *Less Deflection*
 ✓ *Higher Cutting Conditions*

Smooth Cutting

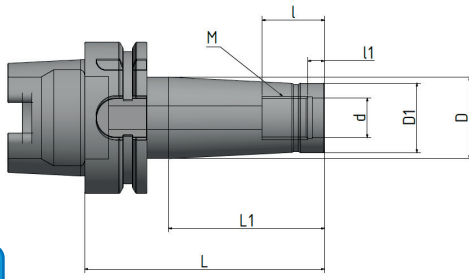

HSK63A

Halter Holder Mandrino	M	L	L1	d(H7)	D1	D	I	Preis Price Prezzo
HSK63A - M 8 - 100T - IDN	8	100	65	8.5	13	23	20	€ 114,00
HSK63A - M10 - 100T - IDN	10	100	65	10.5	18	28	22	€ 114,00
HSK63A - M12 - 100T - IDN	12	100	65	12.5	21	31	25	€ 114,00
HSK63A - M16 - 100T - IDN	16	100	65	17.0	29	34	26	€ 114,00

Erhöhen Sie die Produktivität Ihrer NT-Spannzangenfutter mit den neuen Hochleistungs-Spannmuttern und sparen Sie bis zu 25% !

Upgrade your existing collet chucks with the new high performance cap nuts and **save up to 25% !**

Aggiorna il tuo NT - portapinze con ghiera ad alte prestazioni e **risparmiate fino al 25%.**

5 Spannmuttern Ihrer Wahl bestellen und 1 Rollenschlüssel kostenlos dazu
10 Spannmuttern Ihrer Wahl bestellen und 2 Rollenschlüssel kostenlos dazu

Order 5 Cap Nuts of your choice **and get 1 Roller-Spanner for free**
 Order 10 Cap Nuts of your choice **and get 2 Roller-Spanners for free**

Ordina 5 Ghiere a tua scelta **e ricevi 1 Chiave a rulli gratis**
 Ordina 10 Ghiere a tua scelta **e ricevi 2 Chiave a rulli gratis**

HDP-R

GDP-R

Rollenschlüssel
Roller Spanner
 Chiave a rulli



HDC-A

HDZ

GDC-A

Halter Holder Mandrino	Cap Nut Ghiere	Roller Spanner Chiave a rulli	Preis Price Prezzo
07	HDP-07R	S-0R	€ 80,00
09	HDP-09R	S-1R	€ 70,00
12	HDP-12R	S-3R	€ 80,00
16	HDP-16R	S-4R	€ 90,00
22	HDP-22R	S-5R	€ 110,00

Halter Holder Mandrino	Cap Nut Ghiere	Roller Spanner Chiave a rulli	Preis Price Prezzo
07	HDP-07R	S-0R	€ 80,00
09	GDP-09R	S-1R	€ 95,00
12	GDP-12R	S-3R	€ 105,00
16	GDP-16R	S-4R	€ 110,00
22	GDP-22R	S-5R	€ 125,00

PHC-SA

Dehnspannfutter superschlank
Slim Hydro Chuck
Mandrino Idraulico ultra-sottile



Das Werkzeugspannsystem mit superschlanker Störkontur für Zerspanungsaufgaben an schwer zugänglichen Werkstückstellen

The toolholding system with super slim design. The perfect choice for tight work space applications

Ideale per lavorazioni in aree dai contorni critici, con design super sottile



mehr Info?
einfach
**PHC-SA Katalog
anfordern**

More Info?
just ask for
PHC-SA catalogue

maggiori informazioni ?
semplicemente richiedere
PHC-SA catalogo